

Instrumentation Products

Needle Type Globe Valves and Accessories



Introduction

Introduction

The AS-Schneider Group with its headquarters in Germany is one of the World's Leading Manufacturers of Instrumentation Valves and Manifolds. AS-Schneider offers a large variety of Needle Type Globe Valves for General and Severe Service applications for liquids, gases and steam but also Accessories needed for the instrumentation installations globally.

Selection can be made from a comprehensive range of bodies with a variety of connections and material options, optimising installation and access opportunities. Many of the valves shown in this catalogue are available from stock or within a short period of time. The dimensions shown in this catalogue apply to standard types. If you need the dimensions for your individual type please contact the factory.

Continuous product development may from time to time necessitate changes in the details contained in this catalogue. AS-Schneider reserves the right to make such changes at their discretion and without prior notice.

All dimensions shown in this catalogue are approximate and subject to change.

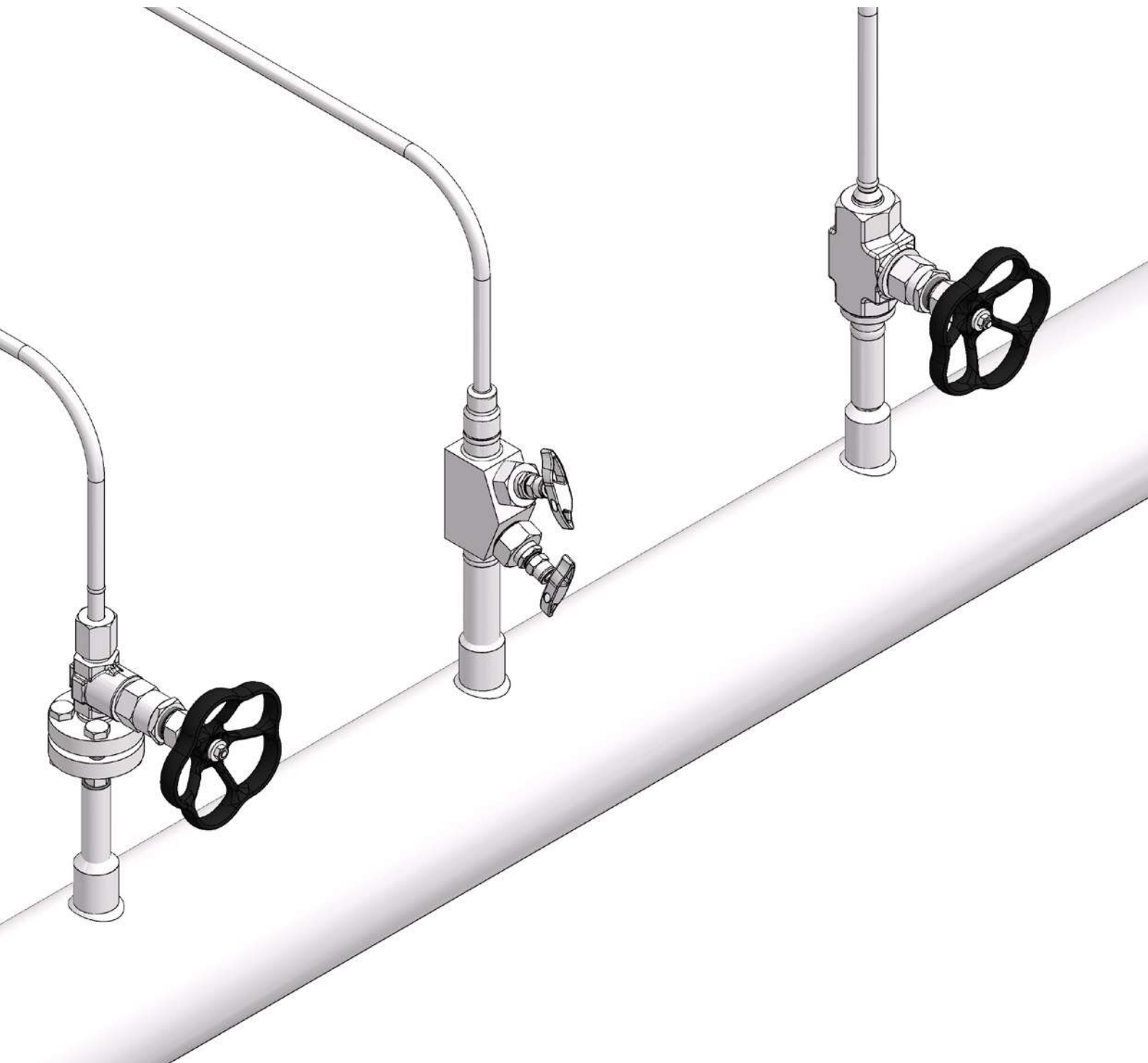

Introduction	page 2
Contents	page 3
Needle Type Globe Valves Overview	page 4-5
General Features and Connections	page 6-7
Integral Bonnet Needle Valves	page 8
Needle Valves Type S338	page 9
Screwed Bonnet Needle Valves Type S350 / F350	page 10
Needle Valves Type S350	page 11
Screwed Bonnet Needle Valves Type A6A	page 12-14
Screwed Bonnet Needle Valves Type A6B	page 15-17
Angle Needle Valves Type S360	page 18
Y-Pattern Needle Valves Type S371	page 19
Union Bonnet Needle Valves Type A1	page 20
Union Bonnet Tandem Valves Type B1	page 21
Ordering Information A1 and B1, Needle Valves	page 22
Condensate Pots	page 23-24
Weld Fittings Tees, Reducers, Connectors	page 25
Threaded Pipe Ends acc. to DIN 19207	page 26
Notes	page 27

Needle Type Globe Valves Overview

Type H

E Series Needle Valves DN 5 / Bore Size 5 mm

- Barstock Body
- Screwed Bonnet
- Integral Valve Seat
- External Stem Thread

Detailed information see Catalogue AS-2601 – E Series Valves and Manifolds - Hand Valves.

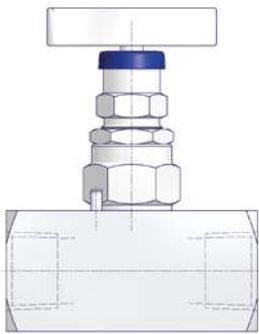

Type S338

Integral Bonnet Needle Valves DN 6 / Bore Size 6 mm

- Forged Body
- Integral Bonnet
- Integral Valve Seat
- Internal Stem Thread

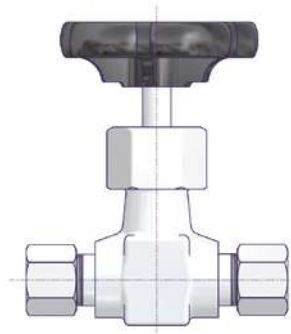

Type S360

Angle Needle Valves DN 8 / Bore Size 8 mm

- Forged Body
- Screwed Bonnet
- Integral Valve Seat
- Internal Stem Thread



Type S371

Y-Pattern Needle Valves DN 8 / Bore Size 8 mm

- Forged Body
- Screwed Bonnet
- Integral Valve Seat
- External Stem Thread



Needle Type Globe Valves Overview

Type A6A

Primary Isolation Valves DN 8 / Bore Size 8 mm

- Forged Body
- Screwed Bonnet
- Replaceable Valve Seat
- External Stem Thread



Type A6B

Needle Valves DN 8 / Bore Size 8 mm

- Forged Body
- Screwed Bonnet
- Replaceable Valve Seat
- External Stem Thread



Type A1 / B1

Union Bonnet Needle Valves

Type A1: DN 11 / Bore Size = 11 mm

Type B1: DN 8 / Bore Size = 8 mm

- Barstock Body
- Union Bonnet Design
- Integral Valve Seat
- External Stem Thread

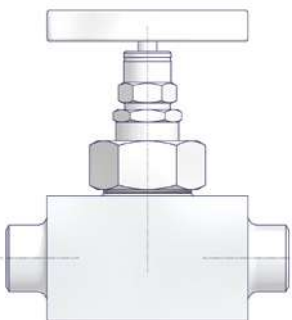

Type A1

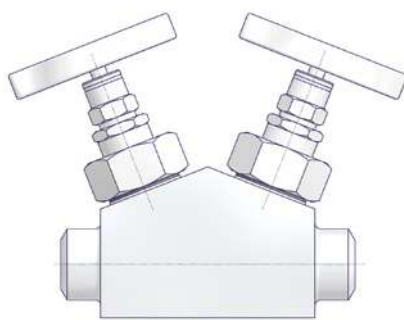

Type B1

General Features

Standard Features

Packing:

PTFE and Graphite Packings are available for all valve types.

Surface Treatment:

Carbon Steel Valves are phosphatized by default.

Pressure Test:

A shell test and a seat test are performed at 1.5 times the max. allowable (working) pressure acc. to EN 12266-1 - P10, P11 and P12 respectively MSS-SP61 at every standard AS-Schneider Needle Type Globe Valve.

Certification:

Inspection certificate 3.1 acc. to EN 10 204 for valve body material and pressure test available on request. The heat resisting materials (see table on Page 6) are available by default with inspection certificate 3.2!

Optional Features

Fugitive Emission Applications:

For Fugitive Emission Applications AS-Schneider is providing bellows sealed valves with safety packing. Choice of Pressure class PN 100 or PN 250 - Suffix P5 or P6.

The bellows are submitted to a 100% Helium leak test. Leak rate: 10^{-8} mbar l/s.

Optional available are TA-Luft and ISO 15848 solutions. For more details please contact the factory.

Oxygen Service:

AS-Schneider offers an option with Reinforced PTFE Packing cleaned and lubricated for Oxygen Service – Suffix F5:

Pressure-Temperature Rating:

Max. 420 bar @ 60°C

Max. 200°C @ 90 bar

Not every Valve type is available for Oxygen Service.

If you don't find your options in this catalogue, please contact the factory.

Valve Head Unit Options

Bellows Sealed Head Units

Bellows Sealed Head Units are mainly used for applications requiring the highest tightness class – such as toxic or vacuum service.

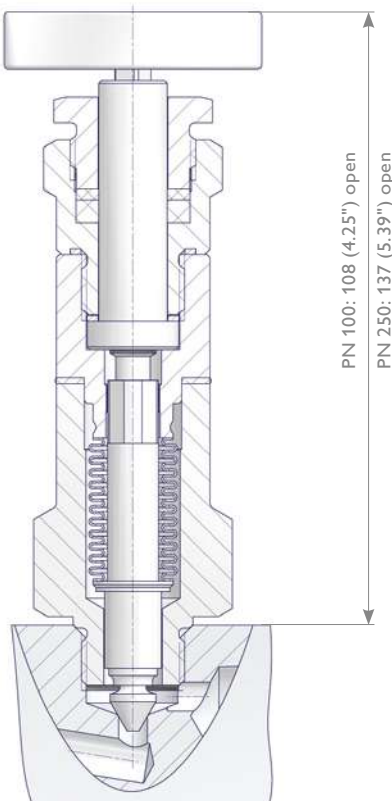

Stem Features

- Stem with cold rolled threads
- Back seat (except Integral Bonnet Needle Valve)
- Non-rotating needle tip or alternatively non-rotating needle

Valve Seat (Metal to Metal)

- Integral Valve Seat or Replaceable Valve Seat

External Stem Thread

External Stem Thread means Packing below Stem Threads. Stem Threads are protected from process media (non-wetted), helps to prevent stems from galling.

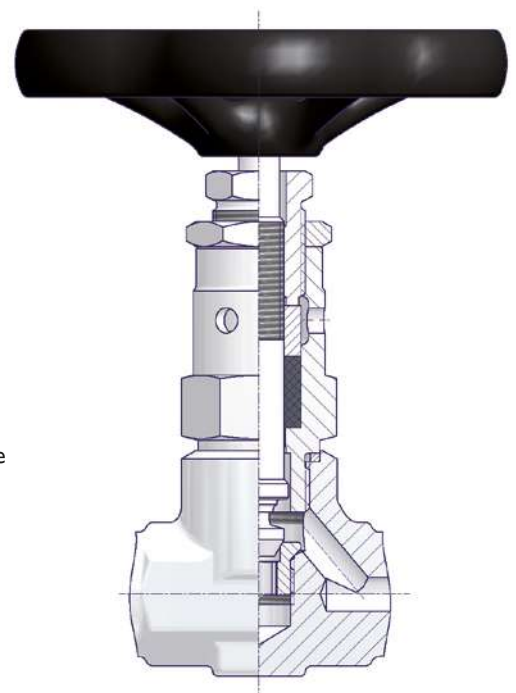

Connections

AS-Schneider is manufacturing a lot of different connections and connection combinations. In this catalogue we are showing the most popular types. On this page you will find the standard connections in detail.

Tube Fittings

Single Ferrule Tube Fittings
acc. to EN ISO 8434-1 Size S

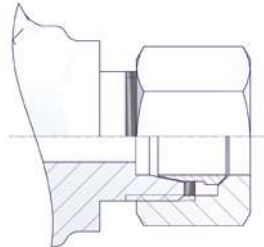

Twin Ferrule Tube Fittings

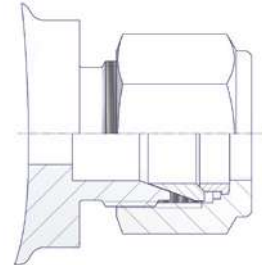

Tapered Pipe Threads

NPT Male Threads
acc. to ASME B 1.20.1

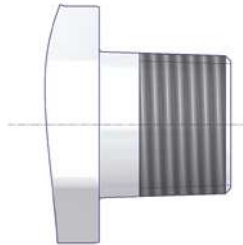

NPT Female Threads
acc. to ASME B 1.20.1

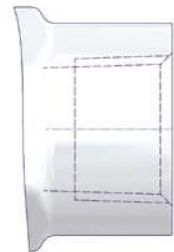

Parallel Pipe Threads

BSP Parallel Male Threads
acc. to DIN 19207 (G1/2)
acc. to DIN 3852

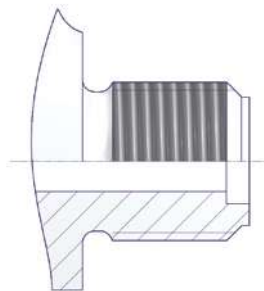

BSP Parallel Female Threads
acc. to ISO 228 (e.g. G 1/2)
acc. to DIN 3852-2 Form Z

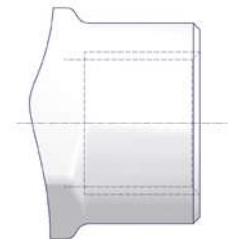

Weld Ends

Butt Weld Ends
for Pipes and Tubes
acc. to ASME B16.9 and
EN 12627

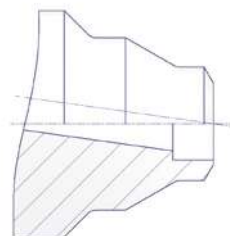

Socket Weld Ends
for Pipes and Tubes
acc. to ASME B16.11 and
EN 12760



Integral Bonnet Needle Valves

Features

- Forged Body - DN 6 / Bore Size 6 mm
- Integral Bonnet
- Integral Valve Seat
- Internal Stem Thread
- Stem with cold rolled surface and non-rotating needle tip
- Standard-Packing PTFE (max. 232°C)
- Optional Graphite Packing (max. 300°C)

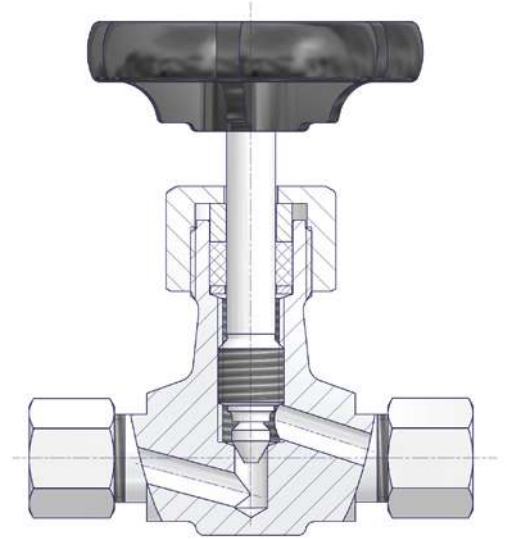

Components	Carbon Steel	Stainless Steel
	Material / Material No.	
Body	1.0460 / A105	1.4571
Valve Stem	1.4104	
Needle Tip	1.4122	
Packing	PTFE (Optional Graphite)	
Union Nut	Unalloyed Steel	1.4571
Tube Fitting		
Handwheel	Plastic	

Pressure-Temperature Ratings

Series S

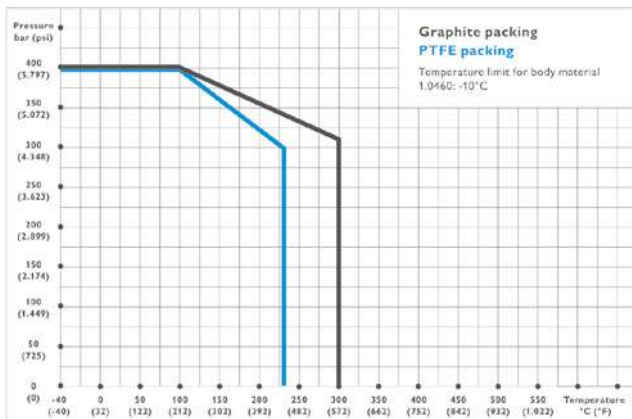

Series L

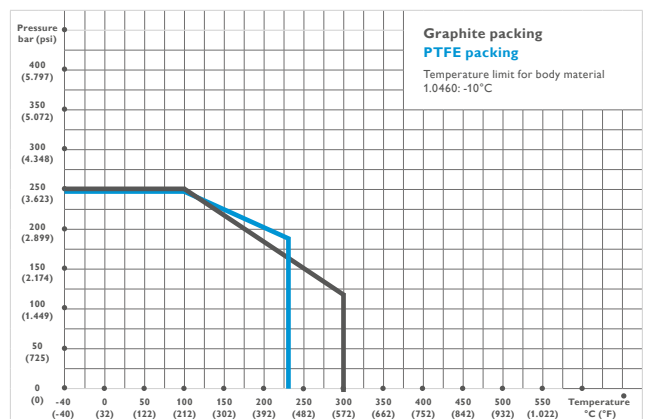

Needle Valves Type S338

Tube Fitting Connections Size S/L

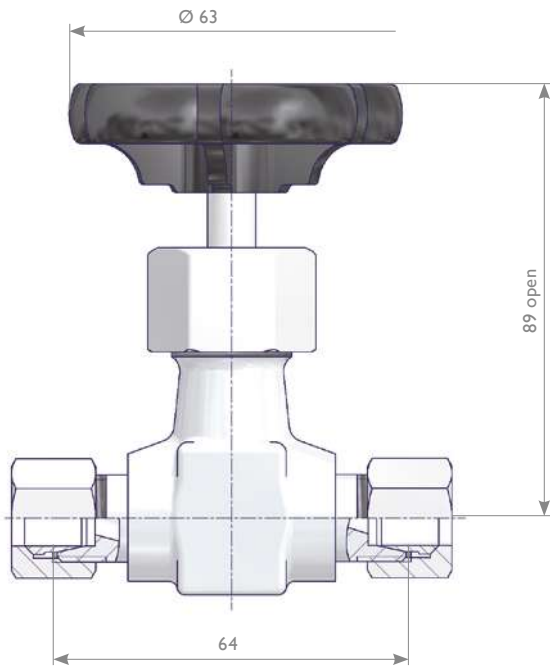

Inlet	Outlet	Part Number	
		Material	
Tube Fitting Sizes		1.0460 / A105	1.4571
6S		S338.03.130	S338.03.230
8S		S338.03.120	S338.03.220
10S		S338.03.110	S338.03.210
12S		S338.03.100	S338.03.200
6L		S338.03.180	S338.03.280
8L		S338.03.170	S338.03.270
10L		S338.03.160	S338.03.260
12L		S338.03.150	S338.03.250

Female Threads

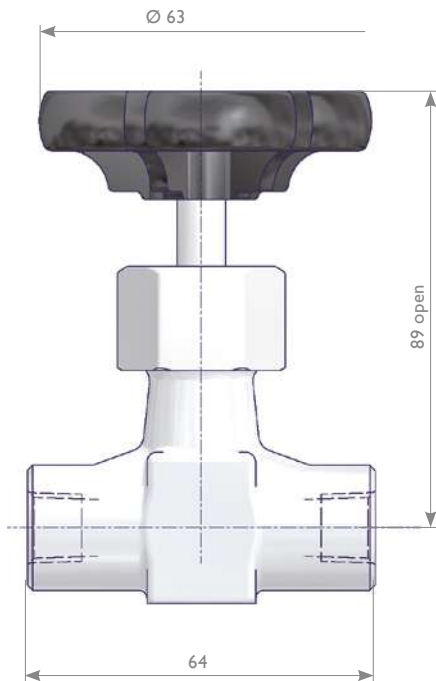

Inlet	Outlet	Part Number	
		Material	
		1.0460 / A105	1.4571
1/4 NPT Female		S338.08.110	S338.08.210
G 1/4 Female		S338.08.115	S338.08.215
G 3/8 Female		S338.08.116	S338.08.216

Screwed Bonnet Needle Valves Type S350 / F350

Features

- Forged Body - DN 8 / Bore Size 8 mm
- Screwed Bonnet
- Replaceable Valve Seat
- Stem with cold rolled surface, back seat and non-rotating needle tip

S350 with Internal Stem Thread

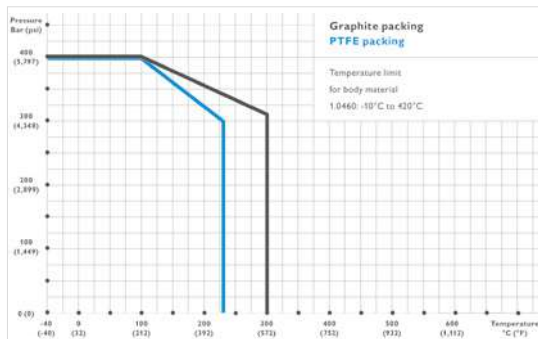
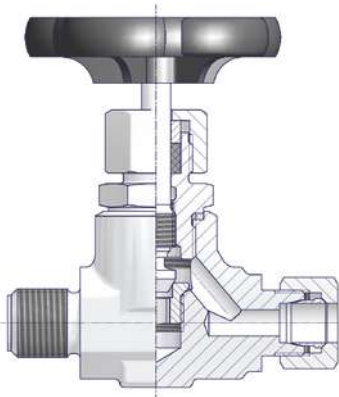

Components	Carbon Steel	Stainless Steel
	Material / Material No.	
Body	1.0460 / A105	1.4571
Bonnet	1.0501	
Valve Seat	1.4571	
Valve Stem	1.4104	
Needle Tip	1.4122	
Packing	PTFE (optional Graphite)	
Union Nut	Unalloyed Steel	1.4571
Tube Fittings		
Handwheel	Plastic	

F350 Bellows sealed option*

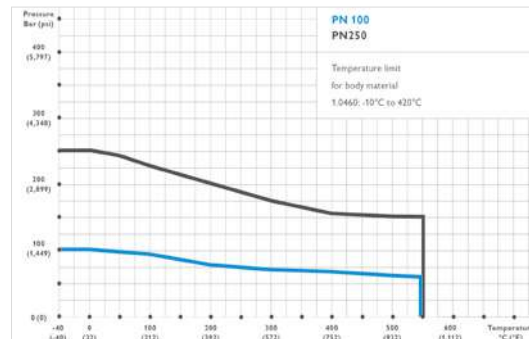
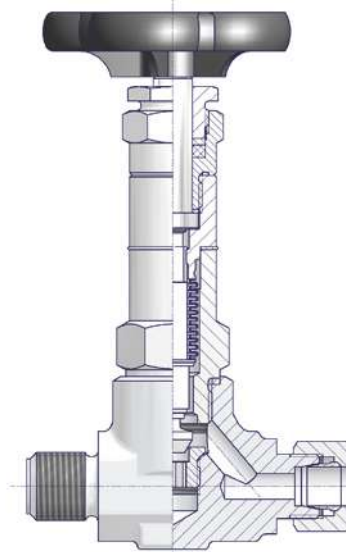

Components	Carbon Steel	Stainless Steel
	Material / Material No.	
Body	1.0460 / A105	1.4571
Bonnet	1.0501	
Bellow	1.4571	
Valve Seat	1.4571	
Valve Stem	1.4104	
Needle Tip	Stellite	
Packing	Graphite	
Stem Nut	1.4122	
Union Nut	1.0501	1.4571
Single Ferrule	1.4571	
Handwheel	Plastic	

The respective max. allowable (Working) Pressure (PS) depends on the tube / pipe connection used. For further information please contact the factory.

* Temperature limit for Carbon Steel -10°C to 450°C.
Temperature limit for Single Ferrule Tube Fitting max. 400°C.

Needle Valves Type S350

Tube Fitting Connections Size S

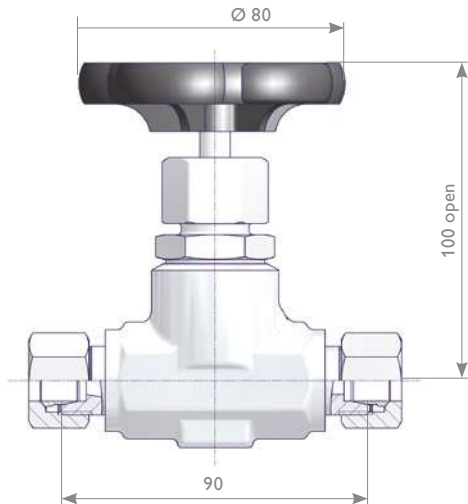

Inlet	Outlet	Material	Part Number
Tube Fitting Sizes			
12S		1.0460 / A105	S350.01.114
		1.4571	S350.01.214
14S		1.0460 / A105	S350.01.115
		1.4571	S350.01.215

Threaded Connections

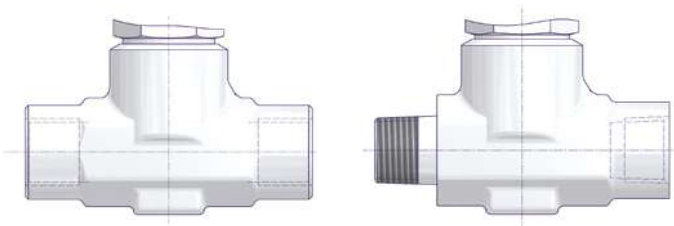

Inlet	Outlet	Material	Part Number
G 1/2 Female		1.0460 / A105	S350.03.104
		1.4571	S350.03.204
1/2 NPT Female		1.0460 / A105	S350.03.124
		1.4571	S350.03.224
1/2 NPT Male	1/2 NPT Female	1.0460 / A105	S350.07.124
		1.4571	S350.07.224

Male Threads DIN 19207 / Tube Fitting Connection*

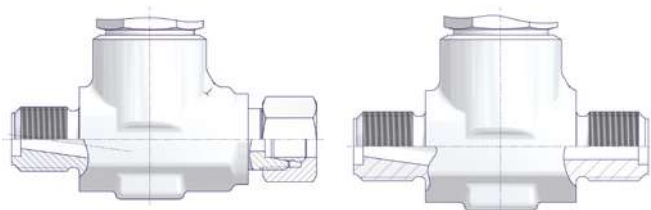

Inlet	Outlet	Material	Part Number
G 1/2 Male DIN 19207 – Type R	Tube Fitting Size 12S	1.0460 / A105	S350.07.114.06
		1.4571	S350.07.214.06
G 1/2 Male DIN 19207 – Type R		1.0460 / A105	S350.09.100.02
		1.4571	S350.09.200.02

* Max. allowable (Working) Pressure (PS) PN 160.

Weld Ends / Tube Fitting Connection

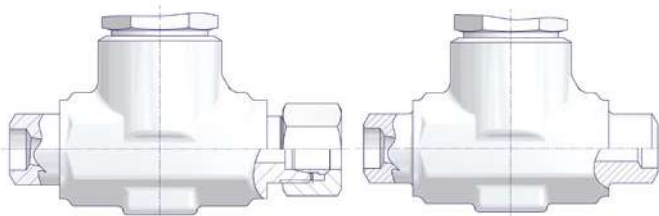

Inlet	Outlet	Material	Part Number
Weld End Ø 21.3 x Ø 12.2	Tube Fitting Size 12S	1.0460 / A105	S350.05.130
		1.4571	S350.05.230
Weld End Ø 21.3 x Ø 12.2		1.0460 / A105	S350.05.100
		1.4571	S350.05.200

Screwed Bonnet Needle Valves Type A6A

Features

- Forged Body - DN 8 / Bore Size 8 mm
- Screwed Bonnet M30x1.5
- Replaceable Valve Seat
- Stem, back seat and non-rotating needle tip
- Butt or Socket Weld Ends
- Face-to-Face 130mm

Needle Valve mainly used as Primary Isolation Valve.

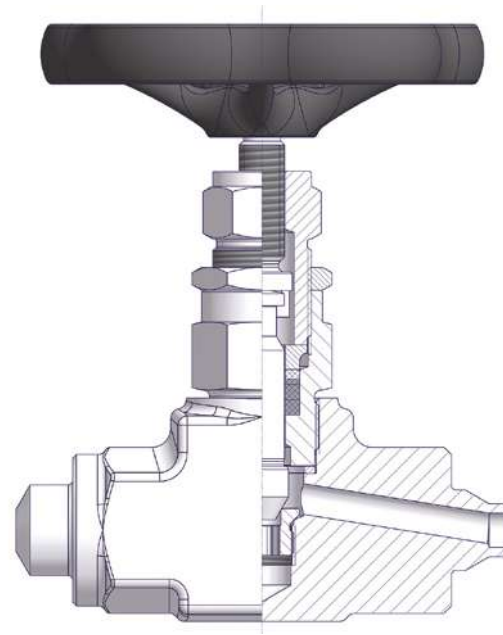

	Certificate 3.1	1.0460/A105	1.4401/1.4404/ F316/F316L	1.5415	1.7335	1.7383
Max. Temperature	-	-29°/420°C	-29°/538°C -60°C mit Arctic Operation	-10°C/ 530°C	-10°C/ 550°C	-10°C/ 550°C
Bonnet	x	1.7709	1.4401/316	1.7709	1.7709	1.7709
Gasket	-	1.7709	1.4571 (316Ti)	1.7709	1.7709	1.7709
Needle	x	1.4122	1.4401/316	1.4122	1.4122	1.4122
Needle Tip	-	Optional in Stellite 6, otherwise Needle as single piece				
Valve Seat	-	1.4021	1.4571 (316Ti)	1.4021	1.4021	1.4981
Valve Seat inlay	-	Optional Valve Seat with welded Stellite 6 inlay				
Stem	-	1.4401/316				
Gland Nut	-					
Lock Nut	-					
Gland	-					
Hand Wheel	-	Steel				

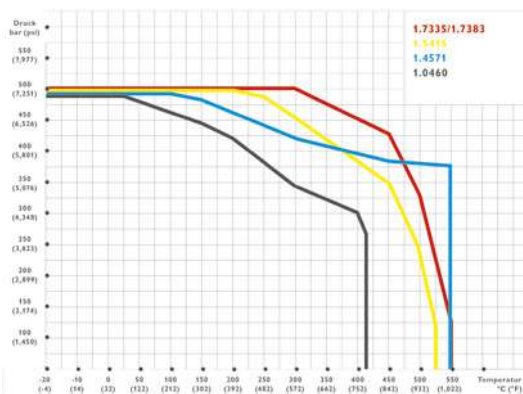

The respective max. allowable (Working) Pressure (PS) depends on the tube / pipe connection used. For further information please contact the factory.

Screwed Bonnet Needle Valves Type A6A

Weld Ends

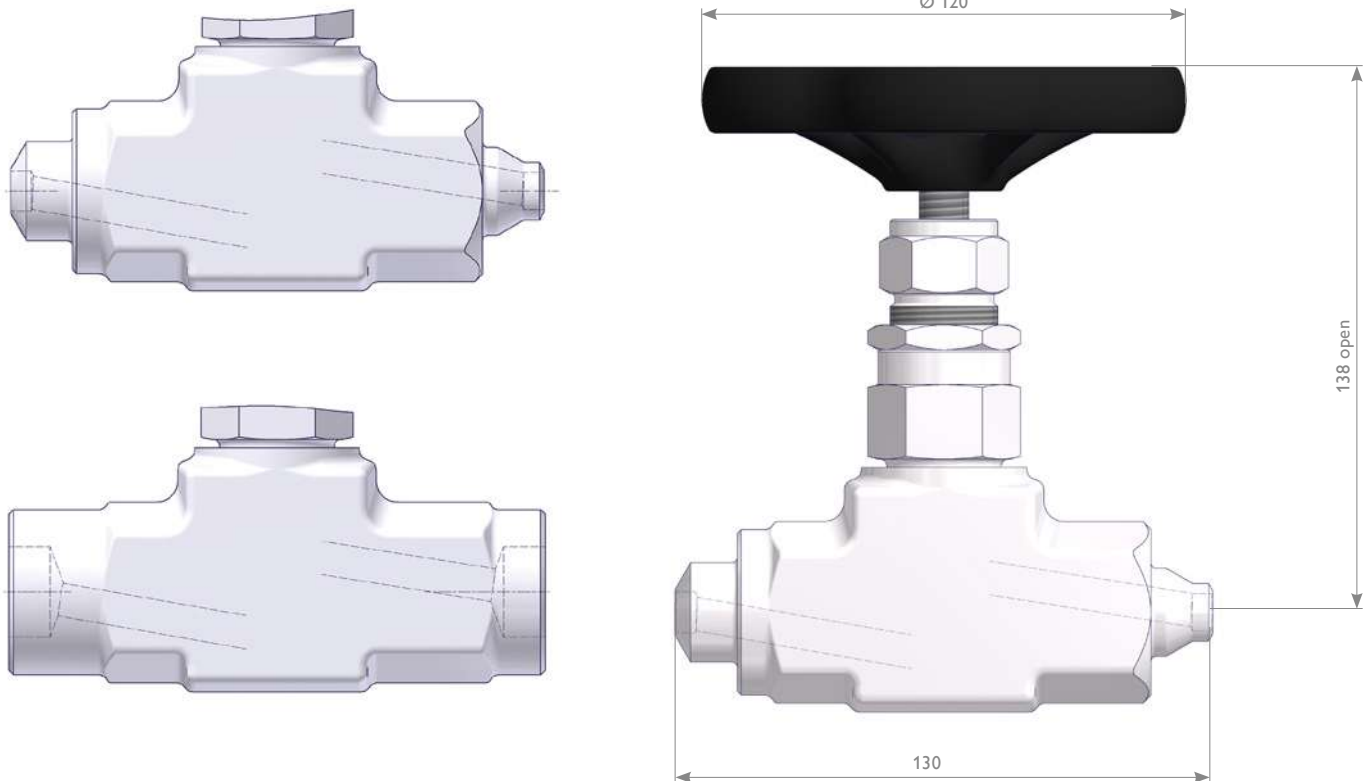

Inlet	Outlet	Material	Part Number
Weld End Ø 21.3 x 2.9	Ø 14 x 2.5	1.0460 / A105	A6ABBCB-49E8
		1.4401/1.4404/ F316/F316L	A6ABBSB-49E8
Weld End Ø 22 x Ø 22		1.0460 / A105	A6ASSCB-4A4A
		1.4401/1.4404/ F316/F316L	A6ASSSB-A4A4

Weld End Connections		Part Number				
		Material				
Inlet	Outlet	1.0460 / A105	1.7335	1.5415	1.7383	1.4401/1.4404/ F316/F316L
Tube Butt Weld End Ø 14 x 2.5		A6ABBCB-E8E8	A6ABBRB-E8E8	A6ABBQB-	A6ABBUB-E8E8	A6ABBSB-E8E8
Pipe Butt Weld End Ø 21.3 x 3.2		A6ABBCB-4343	A6ABBRB-4343	A6ABBQB-4343	A6ABBUB-4343	A6A-BBSB-4343
Pipe Butt Weld End Ø 21.3 x 2.9		A6ABBCB-4949	A6ABBRB-4949	A6ABBQB-4949	A6ABBUB-4949	A6A-BBSB-4949
Pipe Butt Weld End Ø 21.3 x 3.2	Tube Butt Weld End Ø 14 x 2.5	A6ABBCB-43E8	A6ABBRB-43E8	A6ABBQB-43E8	A6ABBUB-43E8	A6A-BBSB-43E8
Pipe Butt Weld End Ø 21.3 x 2.9	Tube Butt Weld End Ø 14 x 2.5	A6ABBCB-49E8	A6ABBRB-49E8	A6ABBQB-49E8	A6ABBUB-49E8	A6ABBSB-49E8
Pipe Butt Weld End Ø 21.3 x 6.3	Tube Butt Weld End Ø 14 x 2.5	A6ABBCB-4FE8	A6ABBRB-4FE8	A6ABBQB-4FE8	A6ABBUB-4FE8	A6A-BBSB-4FE8
Pipe Butt Weld End Ø 24 x 7.1	Tube Butt Weld End Ø 14 x 2.5	A6ABBCB-UGE8	A6ABBRB-UGE8	A6ABBQB-UGE8	A6ABBUB-UGE8	A6A-BBSB-UGE8
Pipe Socket Weld End 1/2"		A6ABBCB-4A4A	A6ABBRB-4A4A	A6ABBQB-4A4A	A6ABBUB-4A4A	A6ASSSB-4A4A

Ordering Information A6A

		1	2	3	4	5	6	7	8	9	10	11	12	13	14	15	16
		A	6	A	B	B	C	B	-	4	3	4	3	-	M	S	
A6	Globe Valves																
Face-to-Face-Length																	
A	130 mm																
Inlet																	
B	Butt Weld End																
S	Socket Weld End																
Outlet																	
B	Butt Weld End																
S	Socket Weld End																
Material																	
C	1.0460 / A105	Q	1.5415*														
S	F316/F316L**	R	1.7335*														
		U	1.7383*														
Bonnet																	
A	PTFE	2	Bellows sealed PN100														
B	Graphite	4	Bellows sealed PN250														
Inlet																	
Butt Weld Ends for Tubes and Pipes. Outside Diameter (O.D.) and Wall Thickness acc. to										Socket Weld End							
ISO 4200, Table 3		ISO 4200, Table 2			ASME B36.10M			Bore acc. to EN 12760 (ASMEB16.11)									
Tube O.D.		Series 1 Pipe O.D.			NPS (Pipe O.D)			For Pipe									
C	10 mm	2	13,5 mm	2	NPS 1/4 (13,7 mm)	2	DN 8 (NPS 1/4)										
D	12 mm	3	17,2 mm	3	NPS 3/8 (17,1 mm)	4	DN 15 (NPS 1/2)										
E	14 mm	4	21,3 mm	4	NPS 1/2 (21,3 mm)	6	DN 20 (NPS 3/4)										
F	16 mm	U	24 mm	6	NPS 3/4 (26,7 mm)	8	DN 25 (NPS 1)										
G	18 mm	6	26,9 mm	8	NPS 1 (33,4 mm)												
J	22 mm	8	33,7 mm														
Wall Thickness in mm		Schedule No.			For Tube O.D												
5	1,5 mm	8	2,6 mm	N	Schedule 40	C	10 mm										
2	2,0 mm	9	2,9 mm	P	Schedule 80	D	12 mm										
8	2,5 mm	3	3,2 mm	Q	Schedule 160	E	14 mm										
9	3,0 mm	A	3,6 mm			F	16 mm										
A	3,5 mm	4	4,0 mm			G	18 mm										
D	5,0 mm	C	4,5 mm			H	NPS 1/2										
		D	5,0 mm			A	Socket Weld End										
		E	5,6 mm			4	1/2"										
		F	6,3 mm														
		G	7,1 mm														
Outlet																	
Butt Weld Ends for Tubes and Pipes. Outside Diameter (O.D.) and Wall Thickness acc. to										Socket Weld End							
ISO 4200, Table 3		ISO 4200, Table 2			ASME B36.10M			Bore acc. to EN 12760 (ASMEB16.11)									
Tube O.D.		Series 1 Pipe O.D.			NPS (Pipe O.D)			For Pipe									
C	10 mm	2	13,5 mm	2	NPS 1/4 (13,7 mm)	2	DN 8 (NPS 1/4)										
D	12 mm	3	17,2 mm	3	NPS 3/8 (17,1 mm)	4	DN 15 (NPS 1/2)										
E	14 mm	4	21,3 mm	4	NPS 1/2 (21,3 mm)	6	DN 20 (NPS 3/4)										
F	16 mm	U	24 mm	6	NPS 3/4 (26,7 mm)	8	DN 25 (NPS 1)										
G	18 mm	6	26,9 mm	8	NPS 1 (33,4 mm)												
J	22 mm	8	33,7 mm														
Wall Thickness in mm		Schedule No.			For Tube O.D												
5	1,5 mm	8	2,6 mm	N	Schedule 40	C	10 mm										
2	2,0 mm	9	2,9 mm	P	Schedule 80	D	12 mm										
8	2,5 mm	3	3,2 mm	Q	Schedule 160	E	14 mm										
9	3,0 mm	A	3,6 mm			F	16 mm										
A	3,5 mm	4	4,0 mm			G	18 mm										
D	5,0 mm	C	4,5 mm			H	NPS 1/2										
		D	5,0 mm			A	Socket Weld End										
		E	5,6 mm			4	1/2"										
		F	6,3 mm														
		G	7,1 mm														
Options - Specify in alphabetical order																	
S	Stellite Valve Tip															M	Wetted Parts with 3.1 certificate
V	Stellite Valve Seat															T	Tandem Valve
Operation Options																	
R	Anti-Tamper Bonnet (1 Key supplied per Valve)															Q	Bonnet with Position Indicator
U	Padlock for Anti-Tamper Bonnet															G	With Mounting Plate

Wetted Parts for Carbon Steel and Stainless Steel are supplied according to NACE MR0175/MR0103 and ISO 15156/17945 (latest issue)
 Note: Not every configuration which can be created in the ordering information is feasible / available.
 *Forgings available for Butt Weld End with NPS 3/4 / Pipe O.D. 26,9 mm resp. Socket Weld End for NPS 1/2 with reduced max. allowable (Working) Pressure.
 ** Quadruple certified F316/F316L/1.4401/1.4404

Screwed Bonnet Needle Valves Type A6B

Features

- Forged Body - DN 8 / Bore Size 8 mm
- Screwed Bonnet M24x1.5
- Replaceable Valve Seat
- Stem, back seat and non-rotating needle tip
- Various connections possible
- Face-to-Face 90mm

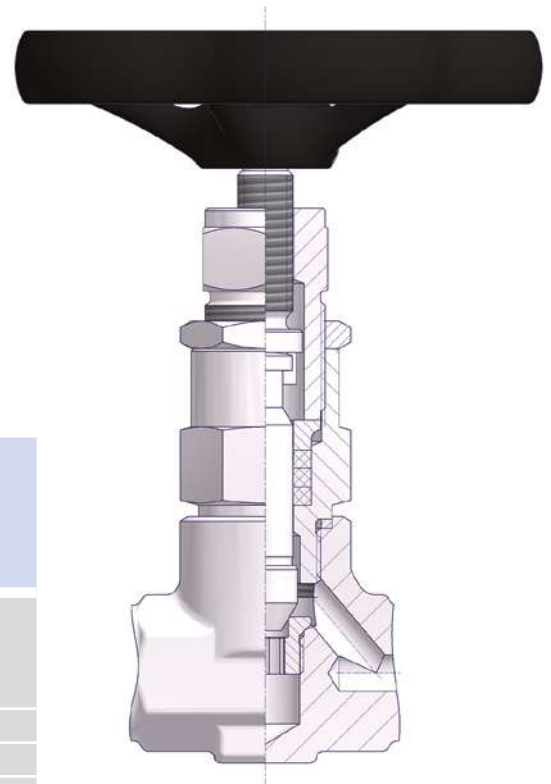

Body (S350.11.x01.01R)	Certificate 3.1	1.0460/A105	1.4571
Max. Temperature	-	-29°/420°C	-40°/538°C -60°C mit Arctic Operation
Bonnet	x	1.7709	1.4401/316
Dichtring (Gasket)	-	1.4571	1.4571
Needle	x	1.4122	1.4401/316
Valve Seat	-	1.4021	1.4571 (316Ti)
Stem	-	1.4401/316	
Gland Nut	-		
Lock Nut	-		
Gland	-		
Hand Wheel	-	Steel	

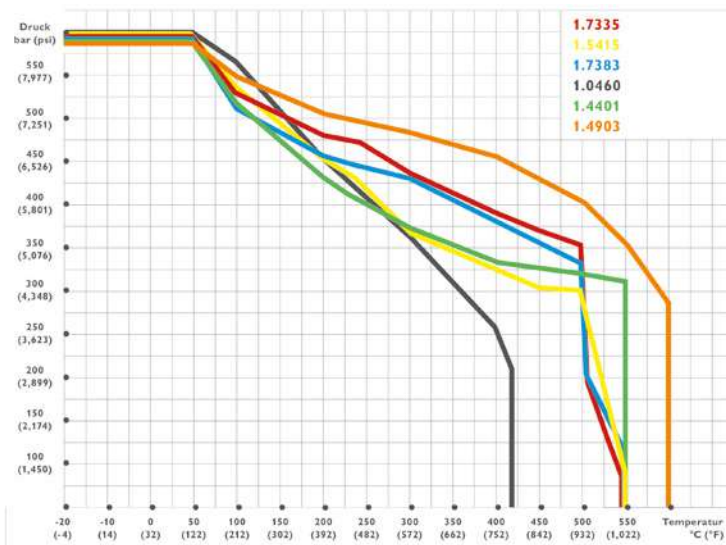

Needle Valves Type A6B

Tube Fitting Connections Size S

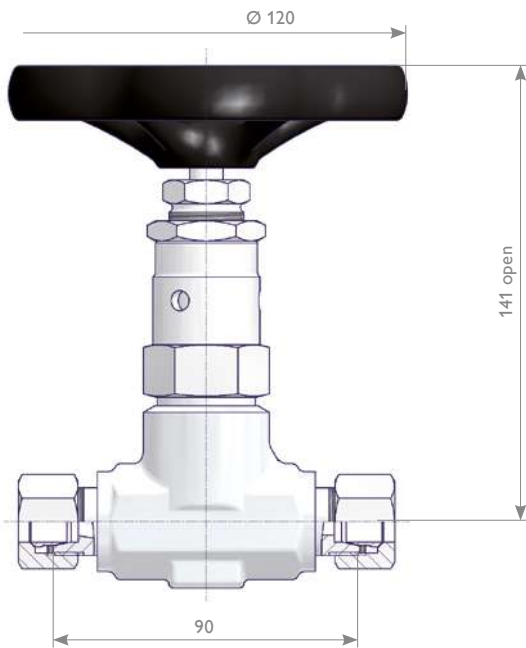

Inlet	Outlet	Material	Part Number
Tube Fitting Size			
12S		1.0460 / A105	A6BTTCB-*4C4
		1.4571	A6BTTPB-*4C4
14S		1.0460 / A105	A6BTTCB-*5C5
		1.4571	A6BTTPB-*5C5

* = Various brands are available

Threaded Connections

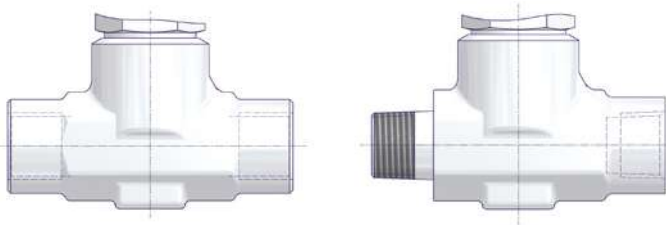

Inlet	Outlet	Material	Part Number
G 1/2 Female		1.0460 / A105	A6BFFCB-HJ4H4
		1.4571	A6BFFPB-HJ4H4
1/2 NPT Female		1.0460 / A105	A6BFFCB-N4N4
		1.4571	A6BFFPB-N4N4
1/2 NPT Male	1/2 NPT Female	1.0460 / A105	A6BMFCB-N4N4
		1.4571	A6BMFPB-N4N4

Weld Ends / Tube Fitting Connection

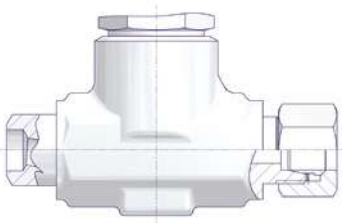

Inlet	Outlet	Material	Part Number
Weld End Ø 21.3 x 4.5	Tube Fitting Size 12S	1.0460 / A105	A6MTCB-4C*4
		1.4571	A6MTPB-4C*4

* = Various brands are available

		1	2	3	4	5	6	7	8	9	10	11	12	13	14	15	16									
		A	6	B	E	T	P	B	-	4	D	C	4	-	M											
A6 Globe Valves																										
Face-to-Face-Length																										
B	90 mm																									
Inlet																										
E	Pipe Butt Weld End x Tube Socket Weld End				F	Female Thread																				
M	Male Thread				T	Integral Tube Fitting																				
Outlet																										
E	Pipe Butt Weld End x Tube Socket Weld End				F	Female Thread																				
M	Male Thread				T	Integral Tube Fitting																				
Material																										
C	1.0460 / A105																									
P	1.4571																									
Bonnet																										
A	PTFE (Bellows sealed PN100)																									
B	Graphite (Bellows sealed PN250)																									
D	ISO FE Series Type 1																									
E	ISO FE Series Type 3																									
W	TA-Luft (PTFE/RPTFE)																									
Inlet																										
Pipe Butt Weld End x Tube Socket Weld End		Thread Type				Fitting Type																				
4	Butt Weld Wend for Pipe O.D.		L N H	DIN 19207 Form R NPT Thread BSP Parallel (G) DIN 3852				C Single Ferrule Tube Fitting K Twin Ferrule Tube Fitting																		
	Socket Weld End for Tube O.D.																		Thread Size				Fitting Size			
	C	10 mm																	4 1/2				4 12 mm resp. 12S			
D	12 mm						5 14 mm resp. 14S																			
Outlet																										
Pipe Butt Weld End x Tube Socket Weld End		Thread Type				Fitting Type																				
	Butt Weld Wend for Pipe O.D.		L N H	DIN 19207 Form R NPT Thread BSP Parallel (G) DIN 3852				C Single Ferrule Tube Fitting K Twin Ferrule Tube Fitting																		
	Socket Weld End for Tube O.D.																		Thread Size				Fitting Size			
		10 mm																	4 1/2				4 12 mm resp. 12S			
	12 mm						5 14 mm resp. 14S																			
Options - Specify in alphabetical order																										
M	Wetted Parts with 3.1 certificate																									
S	Stellite Valve Tip																									
Operation Options																										
R	Anti-Tamper Bonnet (1 Key supplied per Valve)																									
U	Padlock for Anti-Tamper Bonnet																									

Wetted Parts for Carbon Steel and Stainless Steel are supplied according to NACE MR0175/MR0103 and ISO 15156/17945 (latest Issue)
 Note: Not every configuration which can be created in the ordering information is feasible / available.

Angle Needle Valves Type S360

Features

- Forged Body - DN 8 / Bore Size 8 mm
- Screwed Bonnet
- Integral Valve Seat
- Stem with cold rolled surface, back seat and non-rotating needle tip

Please contact the factory for Your Angle Pattern Needle Valve.

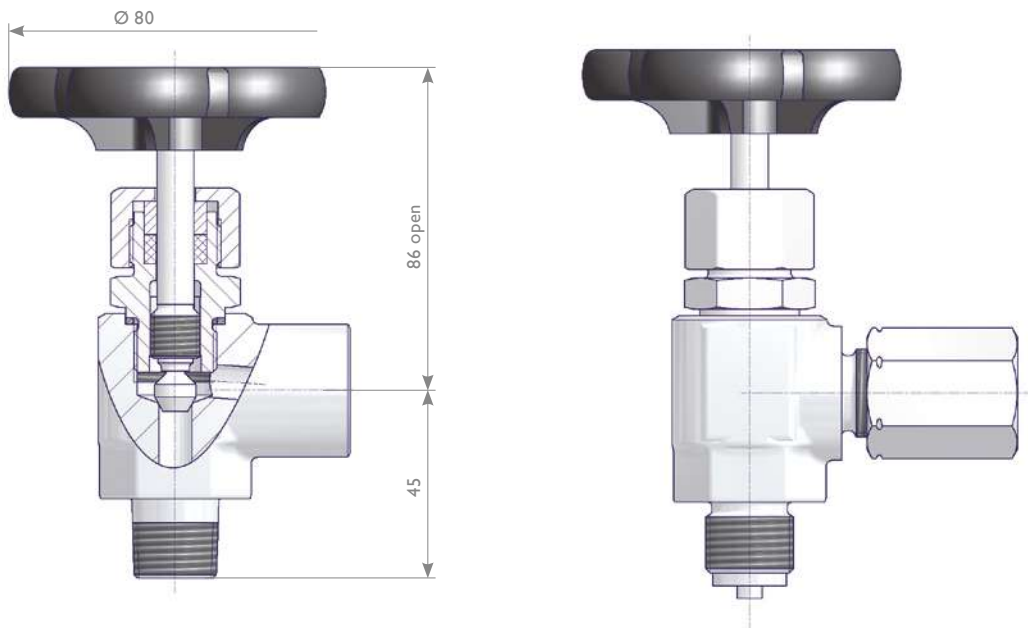

Components	Carbon Steel	Stainless Steel
	Material / Material No.	
Body	1.0460 / A105	1.4571
Bonnet	1.0501	
Valve Stem	1.4104	
Needle Tip	1.4122	
Packing	PTFE (Optional Graphite)	
Union Nut	Unalloyed Steel	1.4571
Tube Fitting		
Handwheel	Plastic	

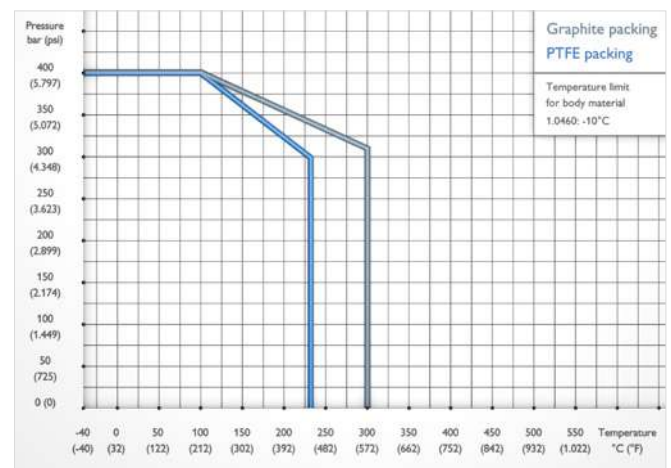

The respective max. allowable (Working) Pressure (PS) depends on the tube / pipe connection used. For further information please contact the factory.

Y-Pattern Needle Valves Type S371

Features

- Forged Body - DN 8 / Bore Size 8 mm
- Screwed Bonnet
- Integral Valve Seat
- External Stem Thread
- Stem with cold rolled surface, back seat and non-rotating needle tip

Please contact the factory for Your Y-Pattern Needle Valve.

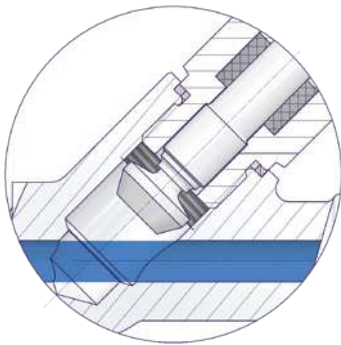
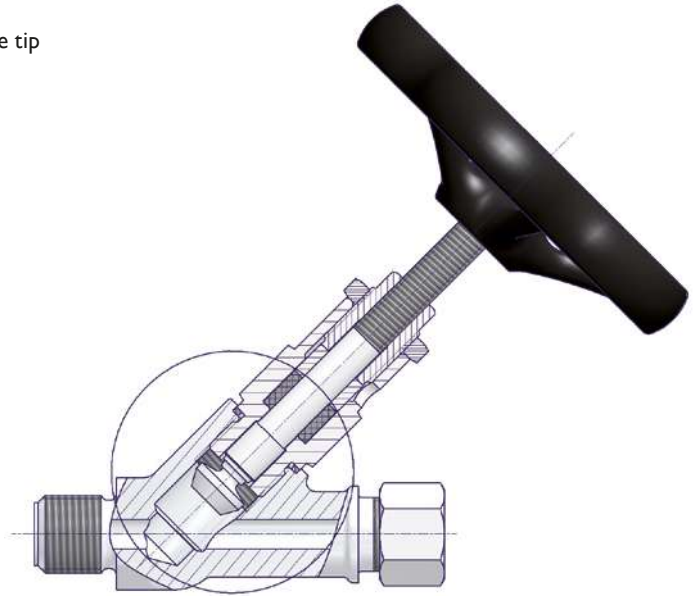

Straight-Through Design
→ Valve is fully roddable

Components	Material / Material No.
Body	1.4571
Bonnet	
Valve Stem	
Needle Tip	
Packing	Graphite
Stem Nut	1.4301
Handwheel	Unalloyed Steel

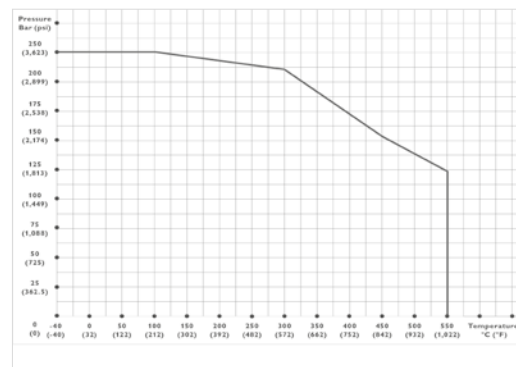

The respective max. allowable (Working) Pressure (PS) depends on the tube / pipe connection used. For further information please contact the factory.

Union Bonnet Needle Valves Type A1

Features

- Barstock Body - DN 11 / Bore Size 11 mm
- Union Bonnet
- Integral Valve Seat
- External Stem Thread
- Valve Stem with cold rolled threads
- Non-rotating Needle and back seat design

Options see Ordering Information on Page 22.

Union Bonnet Needle Valves are designed for Severe Service.

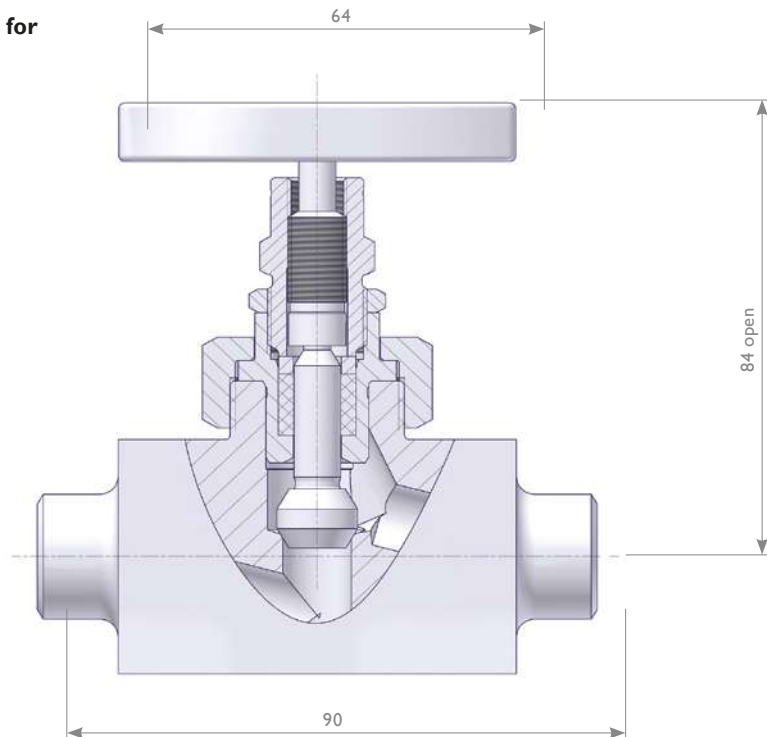

Components	Heat Resistant Steel	Stainless Steel
	Material / Material No.	
Body	1.4903 / F91*	316H
Bonnet	1.4903 / F91	316 / 316L
Valve Stem	1.4404 / 316L	
Needle	1.4923 - Tip Stellite	316 / 316L
Union Nut	1.7709	316 / 316L
Packing	PTFE or Graphite	
Stem Nut	316	
T Bar Handle	Options see Ordering Information	

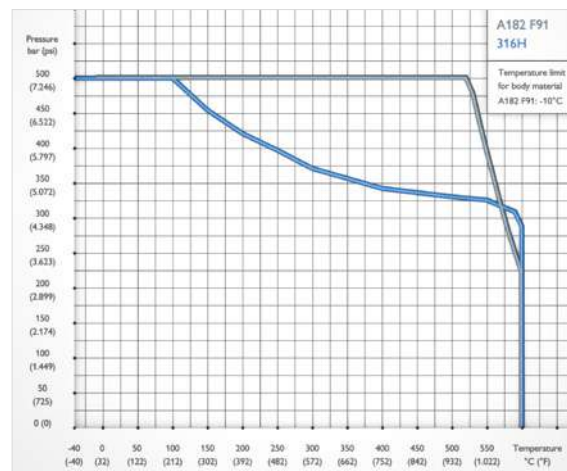

PTFE Packing is limited to 232°C (450°F).

The respective max. allowable (Working) Pressure (PS) depends on the tube / pipe connection used. For further information please contact the factory.

* Welded connections in material 1.4903 / F91 / 1.7335 / 1.7380 require post weld heat treatment (PWHT) at around 700 - 750°C. The valve head unit must be removed prior to the heat treatment to avoid damages. See the installation, operation and maintenance manual for instructions. We recommend to order these valves with 100 mm pipe extensions (Option V - Box 15) to avoid the removal of the valve head units.

Union Bonnet Tandem Valves Type B1

Features

- Barstock Body DN 8 / Bore Size = 8 mm
- Union Bonnet
- Integral Valve Seat
- External Stem Thread
- Valve Stem with cold rolled threads
- Non-rotating Needle and back seat design

Options see Ordering Information on Page 22.

Union Bonnet Tandem Valves are designed for Severe Service.

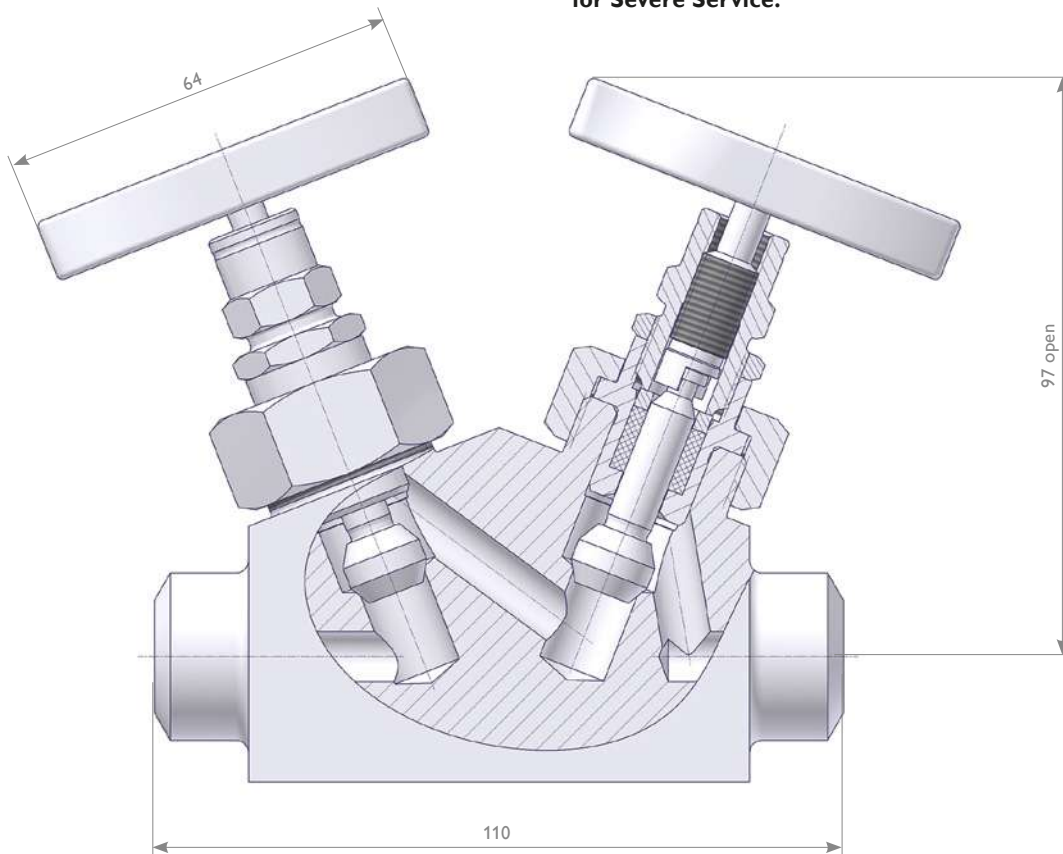

Components	Heat Resistant Steel			Stainless Steel	
	Material / Material No.				
Body	1.4903 / F91*	1.5415	1.7335*	1.7380*	316 / 316L
Bonnet	1.4903 / F91				316 / 316L
Valve Stem	1.4404 / 316L				
Needle	1.4923 - Tip Stellite				316 / 316L
Union Nut	1.7709				316 / 316L
Packing	PTFE or Graphite				
Stem Nut	316				
T Bar Handle	Options see Ordering Information				

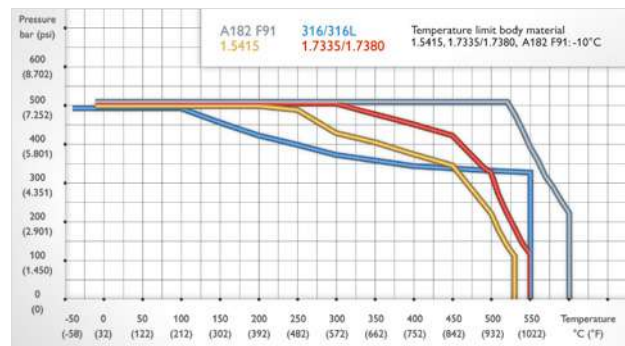

PTFE Packing is limited to 232°C (450°F).

The respective max. allowable (Working) Pressure (PS) depends on the tube / pipe connection used. For further information please contact the factory.

* Welded connections in material 1.4903 / F91 / 1.7335 / 1.7380 require post weld heat treatment (PWHT) at around 700 - 750°C. The valve head unit must be removed prior to the heat treatment to avoid damages. See the installation, operation and maintenance manual for instructions. We recommend to order these valves with 100 mm pipe extensions (Option V - Box 15) to avoid the removal of the valve head units.

Ordering Information | A1 and B1, Needle Valves

		1	2	3	4	5	6	7	8	9	10	11	12	13	14	15
		B	1	B	-	A	4	P	A	4	P	-	S	A		
Valve Type																
A1	Union Bonnet Needle Valve DN11 / Bore Size 11mm															
B1	Union Bonne Tandem Valve DN8 / Bore Size 8mm															
Packing																
A	PTFE															
B	Graphite															
W	Carbon-Filled PTFE – TA-Luft															
Inlet Connection																
A	Butt Weld End															
D	Socket Weld End															
H	Twin Ferrule Tube Fitting															
L	Female Thread															
Pipe / Tube																
4	1/2" pipe	R	Rotarex	N	NPT											
6	3/4" pipe	S	Swagelok													
8	1" pipe															
C	10 mm															
D	12 mm															
E	14 mm															
F	16 mm															
G	18 mm															
K	25 mm															
T	1" tube ^{*1}															
V	1 1/4" tube ^{*1}															
X	1 1/2" tube ^{*1+*2}															
Wall Thickness Pipes / Tubes																
2	2.0 mm	4	12	4	1/2"											
3	3.2 mm	5	14													
4	4.0 mm	6	16													
8	2.6 mm															
A	3.6 mm															
D	5.0 mm															
E	5.5 mm															
G	7.0 mm															
N	Schedule 40															
P	Schedule 80															
Q	Schedule 160															
A	Socket Weld															
Outlet Connection → see Inlet Connection Ordering Information Specifics																
Body Material																
	A1	B1														
R	-	1.7335														
S	316H	316/316L														
U	-	1.7380														
W	F91	F91														
Q	-	1.5415														
Vent Connection																
A	Without															
Operation Options																
B	Handwheel Unalloyed Steel: Standard Option for Needle Valves Type A4															
K	T Handle: Standard Option for Needle Valves Type A1 and B1															
Additional Options																
V	Pipe Extension															

^{*1} Socket Weld End for A2 Needle Valve only.

^{*2} Butt Weld End not available for A1 Needle Valve.

Product Description

Condensate Pots (also called Seal Pots) are used in the measurement of steam or other vapors for two reasons: One reason is that a level of condensed water is accumulated inside of the pot and maintains a fluid volume for displacement equal to or greater than the volume displacement of the transmitter (protecting the transmitter from heat).

The second reason for maintaining a liquid inside of the pot is to prevent flashing of the liquid in the impulse line if a sudden temperature change of the steam is made. A dam inside of the pot prevents this flashing effect.

Pots with more outlet ports for applications where foreign material should be trapped and drained preventing damage of the manifolds and transmitters are also available.

For more details please contact the factory. For details see also DIN 19211.

Condensate Pots for Small Volume Displacements

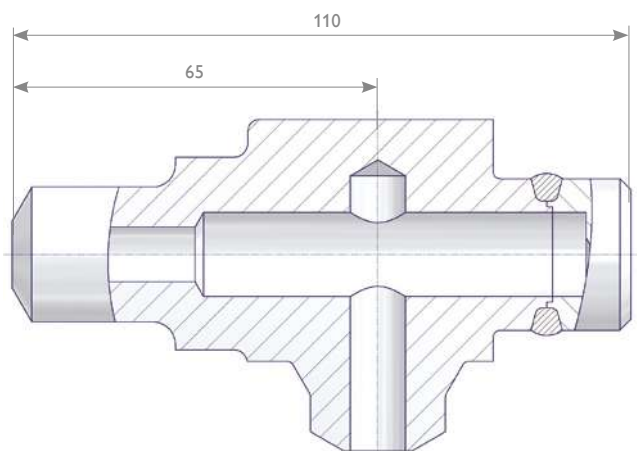

Optional

Condensate Pot / Primary Isolation Valve Assembly - Factory Welded

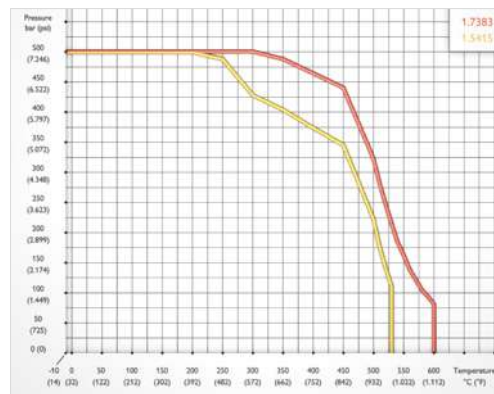
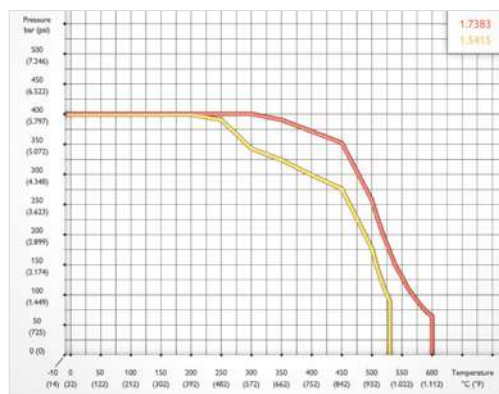

Weld End Connections		Part Number		
		Material		
Inlet	Outlet	1.5415	1.7383	
		PN	Volume (approx.)	
			20 cm ³	20 cm ³
Pipe Butt Weld End Ø 21.3 x 3.2		400	S007.51.603.42	
Pipe Butt Weld End Ø 21.3 x 6.3		500	S007.51.600.45	
Pipe Butt Weld End Ø 24 x 7.1		500	S007.51.600.26	S007.51.500.26

Condensate Pots

Condensate Pots for Larger Volume Displacements

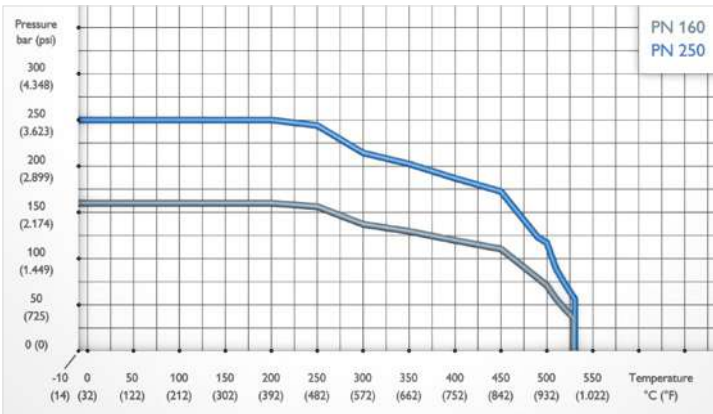
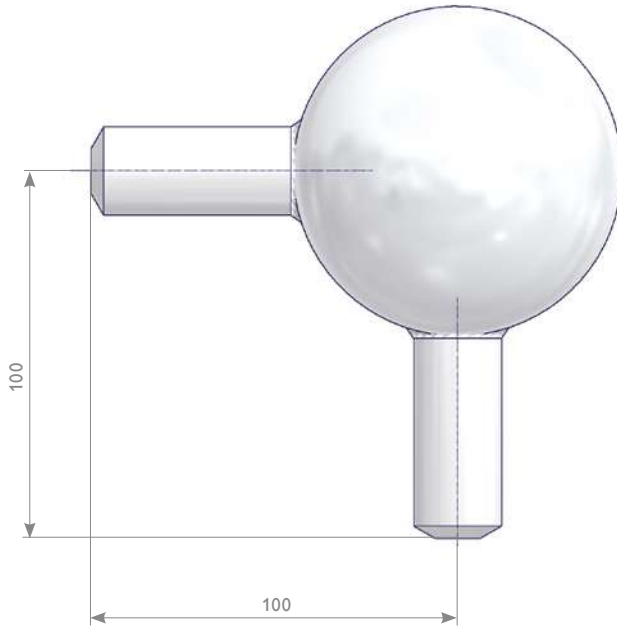

Weld End Connections		Part Number		
		Material 1.5415		
Inlet	Outlet	PN	Volume	
			250 cm ³	700 cm ³
Pipe Butt Weld End Ø 21.3 x 6.3		250	S007.51.653.05	
Pipe Butt Weld End Ø 33.7 x 4.5	Pipe Butt Weld End Ø 24 x 7.1	250		S007.51.653.06
G 1/2 Male DIN 19207 Type R	G 1/2 Male DIN 19207 Type V	160	S007.51.653.04	

Weld Fittings | Tees, Reducers, Connectors

Product Description

AS-Schneider is providing a large range of Weld Fittings – different concerning shape (Tees, Elbows, etc.) and connections (for pipes and tubes) and different in terms of available materials. On this page we are just showing the most used types.

If you don't find your option please contact the factory.

Tees

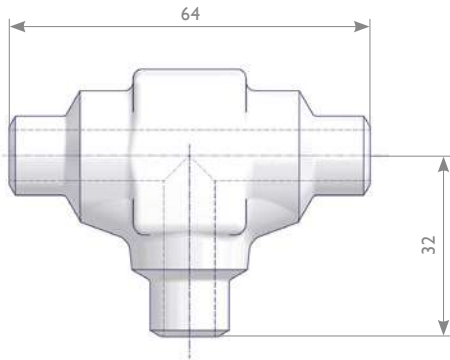

Weld End Connections	Part Number		
	Material		
	1.5415	1.7335	1.4571
Pipe Butt Weld End Ø 21.3 x 3.2	S006.40.610.43		S006.40.210.43
Tube Butt Weld End Ø 14 x 2.5	S006.40.600	S006.40.101	S006.40.200
Tube Socket Weld End Ø 12			S006.40.210

Reducers (Pipe Butt Weld x Tube Butt Weld)

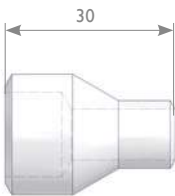

Weld End Connections		Part Number	
		Material	
		1.5415	1.4571
Pipe Butt Weld End Ø 21.3 x 3.2	Tube Butt Weld End Ø 12 x 1.5		S006.40.230.20
Pipe Butt Weld End Ø 21.3 x 3.2	Tube Butt Weld End Ø 14 x 2.5	S006.40.630.14	S006.40.230.14
Pipe Butt Weld End Ø 33.7 x 4.5	Tube Butt Weld End Ø 14 x 2.5	S006.40.632.84	S006.40.232.84

Connectors (Pipes and Tubes)

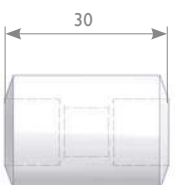

Weld End Connections	Part Number	
	Material	
	1.5415	1.4571
Weld End Ø 21.3 x Ø 12.2		S006.40.220
Weld End Ø 21.3 x Ø 14.25	S006.40.120.04	S006.40.220.04

Threaded Pipe Ends acc. to DIN 19207

Product Description

DIN 19207 is defining 2 different Threaded Connections (Type V and Type R) to be used either for a Flanged Connection with Threaded Flanges or a Nipple Connection. For more details see DIN 19207. The max. allowable (Working) Pressure (PS) for this connection is defined at 160 bar.

Valves with DIN 19207 connections see Page 7, condensate pots see Page 23 and 24.

Flange Connection I Accessory Kit

Mounting Kit contains	Material	Part Number
4 Hexagon Nuts DIN EN ISO 4032 - M10 4 Hex Cap Screws DIN EN ISO 4014 - M10 x 45	Carbon Steel Nuts and Screws 1.1181, Gasket 1.4571, Flange 1.0460	S006.39.100.02
1 Grooved Gasket DIN 19207 - B 1/2 2 Threaded Flanges DIN 19207 - G 1/2	Stainless Steel Nuts A4-70, Screws A2-70, Gasket 1.4571, Flange 1.4571	S006.39.200.02

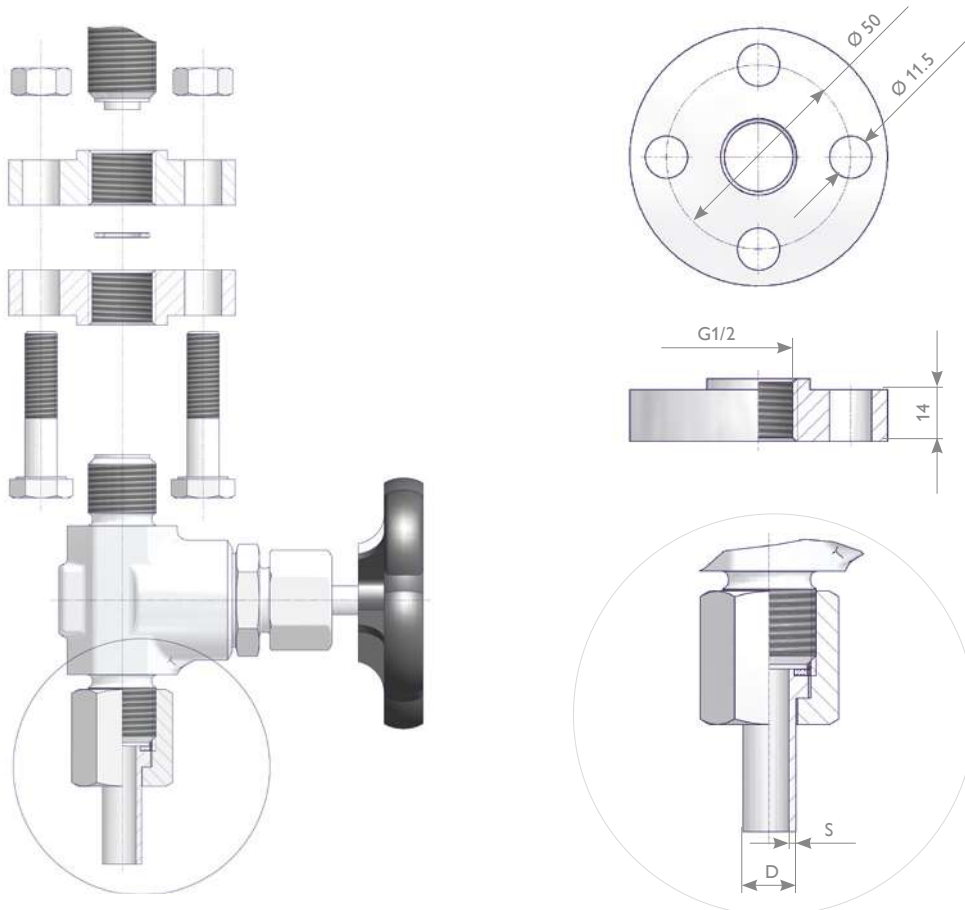

Nipple Connection I Accessory Kit

Union Nut		Nipple		Grooved Gasket	Accessory Kit
Thread	Material	D	s	Material	Part Number
G 1/2	1.1181	12	1.65	1.4571	S007.45.103.10
	1.4571				S007.45.203.10
	1.1181	14	2.5		S007.45.103.11
	1.4571				S007.45.203.11

YOUR GLOBAL PARTNER

for Instrumentation and
Double Block & Bleed Valves



Visit us on:



ARMATURENFABRIK FRANZ SCHNEIDER GMBH + CO. KG
World Headquarters
Bahnhofplatz 12, 74226 Nordheim, Germany
Tel: +49 7133 101-0
www.as-schneider.com



ARMATURENFABRIK FRANZ SCHNEIDER SRL
Gradinari 32-38, 100404 Ploiesti
Romania
Tel: +40 244 384 963
www.as-schneider.ro



AS-SCHNEIDER ASIA-PACIFIC PTE. LTD.
970 Toa Payoh North, #02-12/14/15, Singapore 318992,
Singapore
Tel: +65 62 51 39 00
www.as-schneider.sg



AS-SCHNEIDER AMERICA, INC.
17449 Village Green Dr, Houston, TX 77040
United States of America
Tel: +1 281 760 1025
www.as-schneider.com



AS-SCHNEIDER MIDDLE EAST FZE
P.O. Box 18749, Dubai
United Arab Emirates
Tel: +971 4 880 85 75
www.as-schneider.ae



AS-SCHNEIDER INDIA PRIVATE LIMITED
Rathinam Techzone Campus, Eachanari
641021 Coimbatore, Tamil Nadu, India
Tel: +91 999 544 2201
www.as-schneider.com

